

## Guidance for Iowans to sew cloth gowns for healthcare providers

Issued: 04/05/2020

There is a national shortage of commercially-produced PPE including gowns. Public and private officials are working to address national and global supply challenges. Due to the current limitations on supplies of disposable and cloth gowns, there may come a time during this response when commercially manufactured gowns are no longer readily available. Iowans who would like to support healthcare providers can use this guidance document to construct homemade washable cloth gowns that can be worn by Iowa healthcare providers during patient care. Homemade washable cloth gowns are typically made of polyester or polyester-cotton fabrics. Gowns made of these fabrics can be safely laundered using routine procedures and reused.

Iowans who would like to donate homemade gowns need to call their local hospital, medical clinics, or long-term care facility prior to making a donation. The facility will provide guidance on where to drop off donations outside of the health care facility. There are many different patterns available on the internet, please choose one that meets the specifications below or one that meets the requirements provided by the facility where you are making a donation.

### Measurements for Small/Medium Gowns

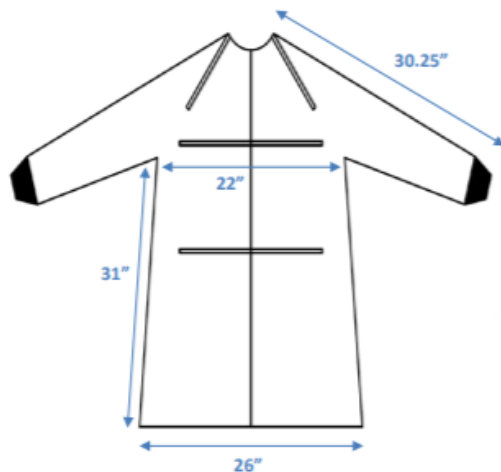

### Measurements for Large/Extra Large Gowns

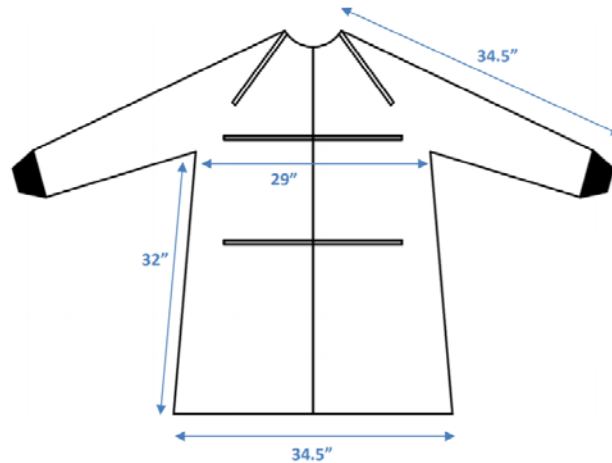

Additional sample patterns can be found at:

<https://ukhealthcare.uky.edu/sites/default/files/isolation-gown.pdf>

<https://www.fashiongirlsforhumanity.org/products/gown-pattern-package>